



JNM
Engineering

Design of Dale Creek Dam

Nick Berling, Matt Jensen,
Jacob Woicik

5/2/2015

Overview

- Location and Purpose
- Summary of Design
- Design Data
 - Reservoir
 - Damsite
- Design
 - Dam
 - Outlet Works
 - Spillway
- Construction Facilities
- Materials and Unit Prices
- Environmental and Ecological Measures
- Conclusion

Location and Purpose

- Location
 - Section 10 & 15, T13N, R72W
 - 6 miles south west of Turtle Rock
 - 3.5 miles west south west of Ames Monument
 - Access via County Road 222/Hermosa Rd.
- Purpose
 - To provide new water and domestic storage of excess Cheyenne water for the municipality of Burns
 - Provide domestic storage for water flowing in the Lake Owen-Granite Springs reservoirs
 - Water surface elevation at 8000 feet
 - Dead pool surface elevation at 7934 feet

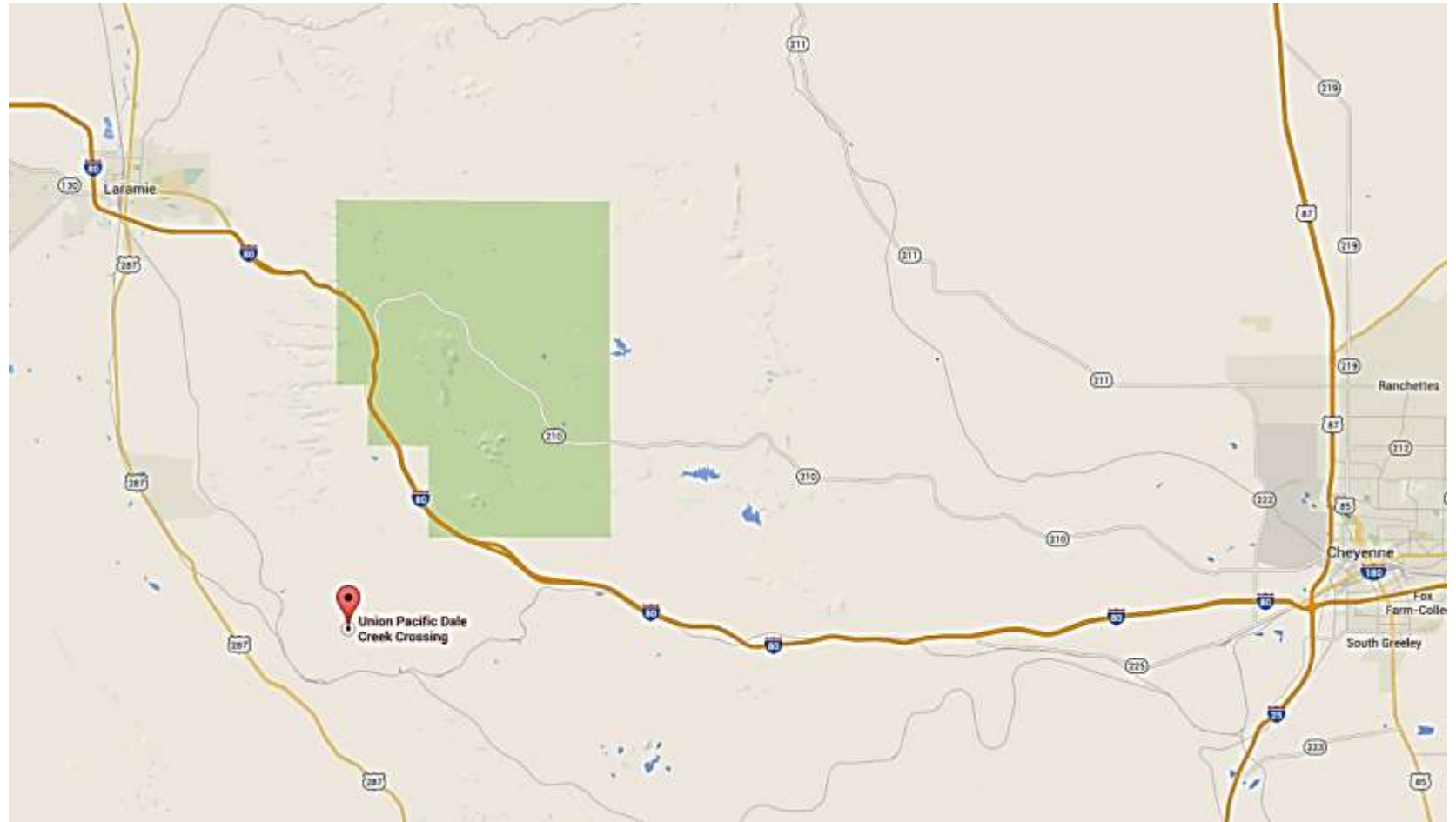

Alternate Designs

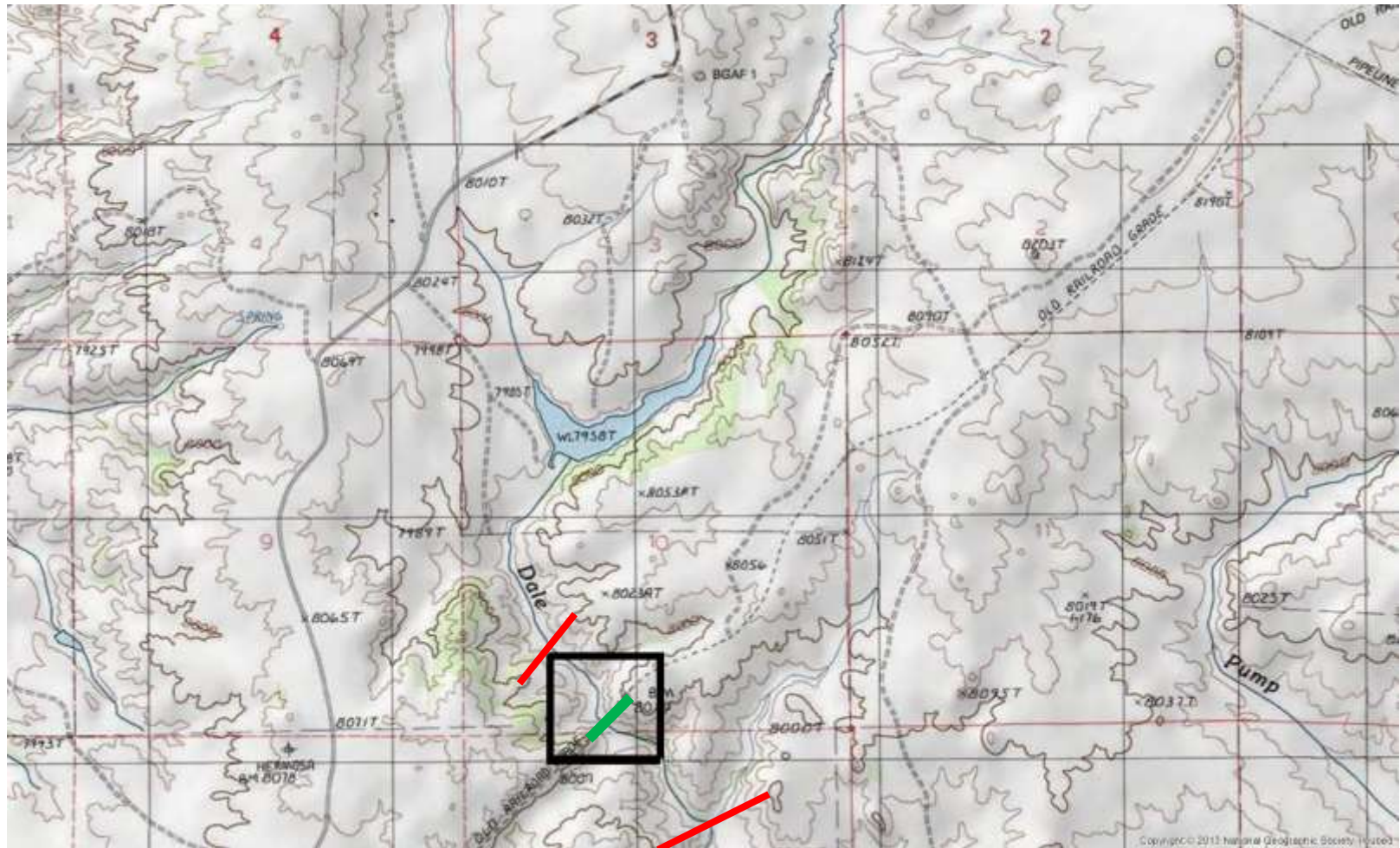

Summary of Design

- Storage capacity: 12721 acre-feet
- Spillway capacity: 2265 cfs
 - Water surface elevation 8005
- Outlet capacity: 180 cfs
 - Water surface elevation 8000
- Top of dam: elevation 8020
- Normal water surface: elevation 8000
- Maximum water surface: elevation 8015
 - Surcharge 19,813 acre feet
- Minimum water surface: elevation 7934
- Free board above maximum high water: 5 feet
- Maximum height of dam above streambed: 120 feet
- Estimated cost of dam: \$32,700,000.00
- Estimated cost per acre-foot of storage: \$3,400.00
- Total estimate, project: \$43,255,000.00

Design Data

- Topography
 - Scale: 1:24000
 - 40 foot contour interval
 - Surveyed by US Geological Survey in 1987
- Dale Creek Soils Report, Dr. Thomas Edgar, P.E.
- Hydrographs of Dale Creek water shed
- Borrow areas/Aggregate Deposits
 - Core (Zone 1): TP3 scraper haul
 - Shell (Zone 2): TP1, scraper haul

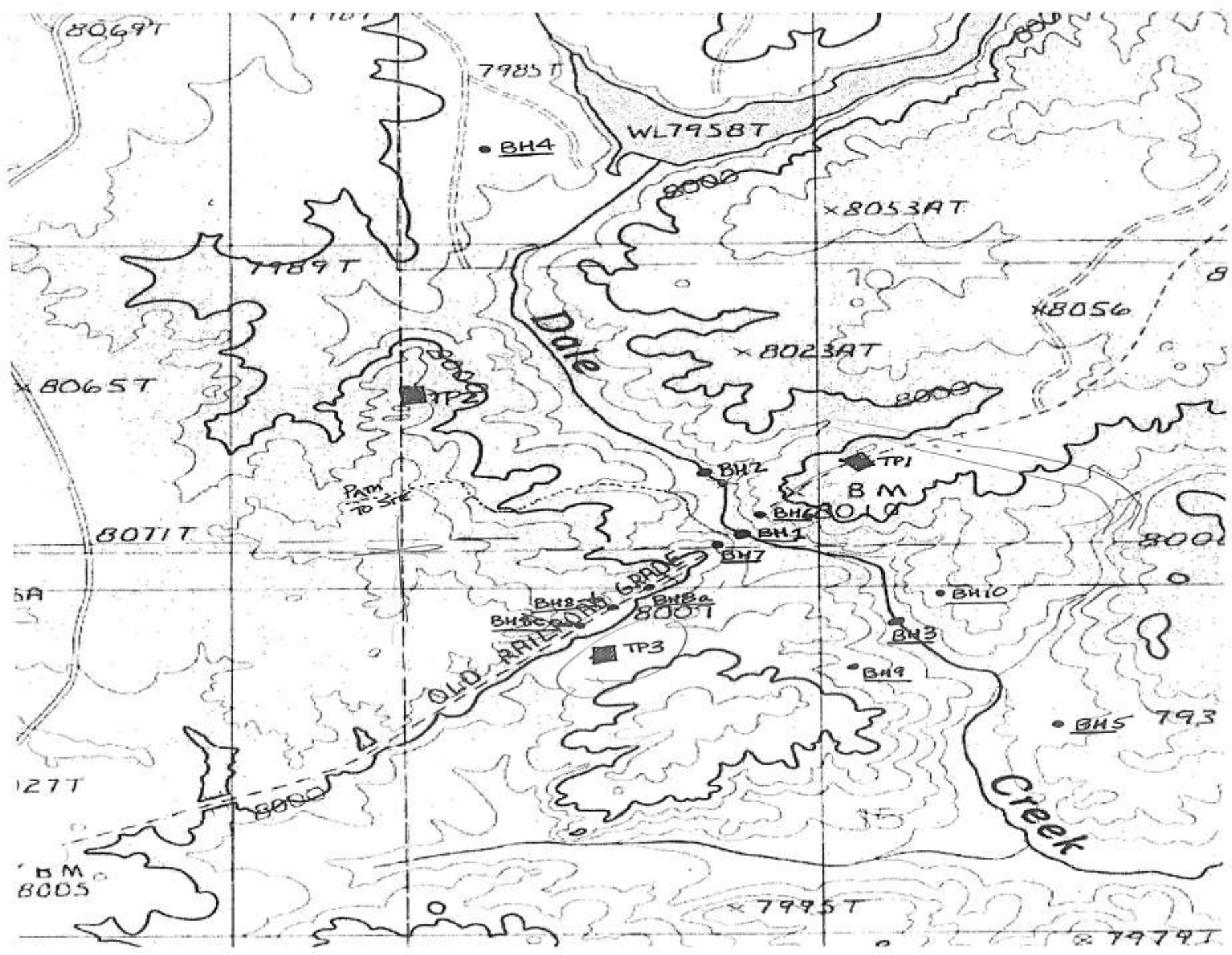



Date: _____

Class: _____

Assignment: _____

EL 7900'	BH 1	0-3 ^{ft} 3-25 ^{ft}	SAND + GRAVEL, ORGANICS, WILLOW BUSHES SW GRANITE, COMPETENT, LARGE GRAIN, MOD. FRACTURE RQD - 75 POSSIBLE SHEAR ZONE @ 15'
EL 7908'	BH - 2	0-4 ^{ft} 4-25 ^{ft}	SILTY SAND GRAVEL, ORGANICS, WILLOWS SW GRANITE, COMPETENT, SHEAR @ 15' RQD - 65, SOME FRACTURE
EL 7885'	BH - 3	0-5 ^{ft} 5-25 ^{ft}	SAND + GRAVEL, SOME FINES, SOME ORGANICS SP - SM GRANITE COMPETENT, SHEAR @ 25' RQD - 65, SOME FRACTURE
EL 8080	BH - 4	0-5" 5"-14 ^{ft} 14 ^{ft} -17 ^{ft} 17 ^{ft} -25 ^{ft}	ORGANIC TOP SOIL SANDY SILTY CLAY SC/CL LOW MOISTURE CONTENT WEATHERED GRANITE GRANITE
	BH 5	0-10 ^{ft} 10-25 ^{ft}	SAND, SOME GRAVEL, SOME SILT SP - SM BEDROCK
EL 7960	BH 6	0 ^{ft} -25 ^{ft}	MIXED COMPETENT AND WEATHERED BEDROCK MASSIVE VERTICAL FRACTURING. LOOSE ROCK
EL 7960	BH 7	0 ^{ft} -25 ^{ft}	As BH 6
EL 8014	BH 8 a	0-6 ^{ft}	RAILROAD EMBANKMENT RANDOM COARSE TO COBBLES No Sample
	BH 8 b	0-3 ^{ft}	As BH 8 a
	BH 8 c	0-4 ^{ft}	As BH 8



Date:

Class:

Assignment:

EL-7940 BH-9 0-3^{ft} ORGANIC SANDY SILT
 0-15^{ft} FRACTURED WEATHERED GRANITE RQD -25
 15^{ft}-25^{ft} COMPETENT GRANITE RQD 65

EL 7942 BH-10 AS BH-9

		-200Z	LL	PL	W	
BH-3	SAND	7%	—	NP	25%	
BH-4	SANDY SILTY CLAY	40-54%	43	17	12%	6'
			36	13	13%	10'
			38	12	15%	14'
TP3		60%	52	19	18%	
BH-5	SAND	8%	22	18	12%	

S_u = 23 psi
W = 16%



Date: _____

Class: _____

Assignment: _____

EL ~~8030~~ TP1 - ^{TOP of} RAIL ROAD GRADE
8030'

0-12' RAILROAD EMBANKMENT - 30% BOULDERS, 30% COBBLES, 20% GRAVEL,
12% SAND, 6% SILT GP-GM, RANDOM FILL., IRREGULAR
SLOPE TO 45° MAX., DRY TO MOIST, ANGULAR TO
ROUNDED

12'-15' LOESS, COLLAPSED, WET

15'-16' WEATHERED GRANITE

EL 8050' TP2 0-2" SILTY SAND - ORGANIC TOPSOIL

2" - 6' SANDY, SILTY CLAY SC/CL
MOIST, MODERATE CONSISTENCY

6' WEATHERED BEDROCK

EL ~~7993~~ TP3 - 0-9" ORGANIC TOP SOIL

9"-14^{ft} SANDY SILTY CLAY CL

14^{ft}-18^{ft} WEATHERED BEDROCK

18^{ft} COMPETENT BEDROCK

$$K_x = 5.6 \times 10^{-6} \text{ cm/sec}$$

$$K_z = 0.6 \times 10^{-6} \text{ cm/sec}$$

98% compaction
+ 2% optimum

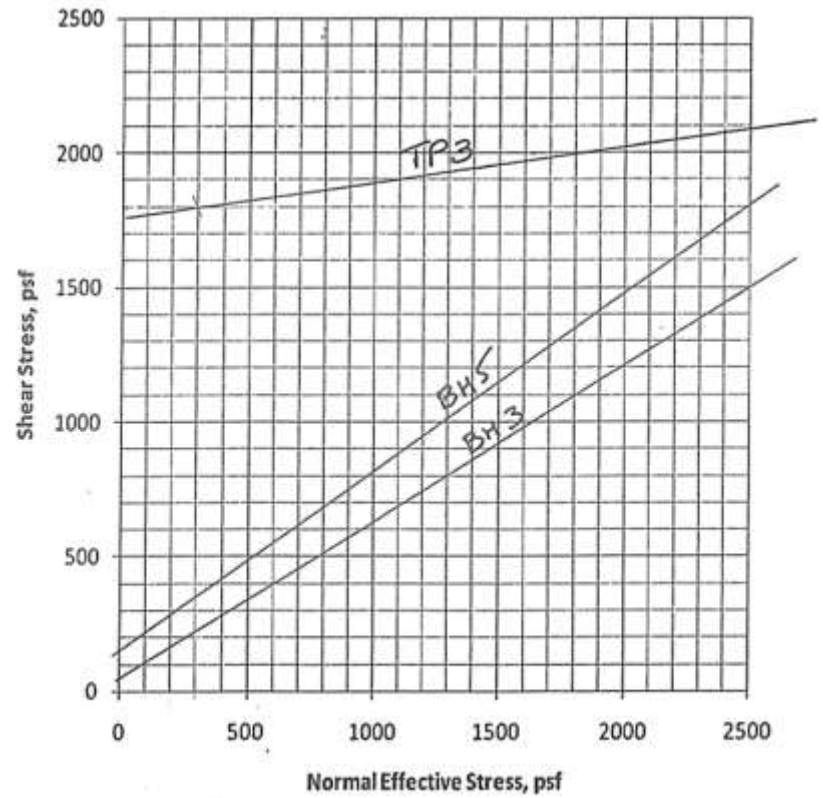
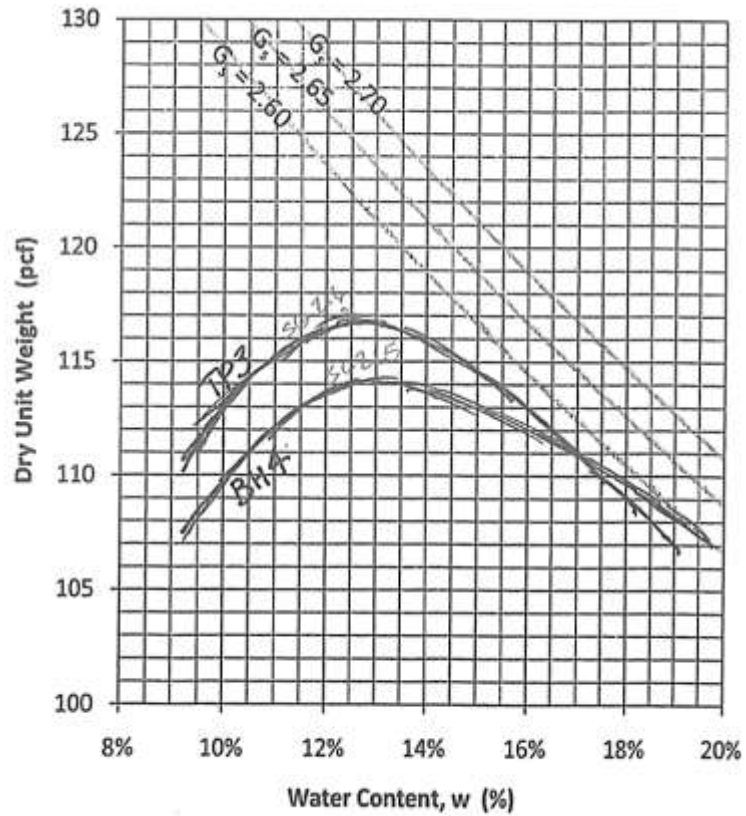

Grain Size Distribution

Gravel		Sand			Silt	Clay
Coarse	Fine	Coarse	Medium	Fine		

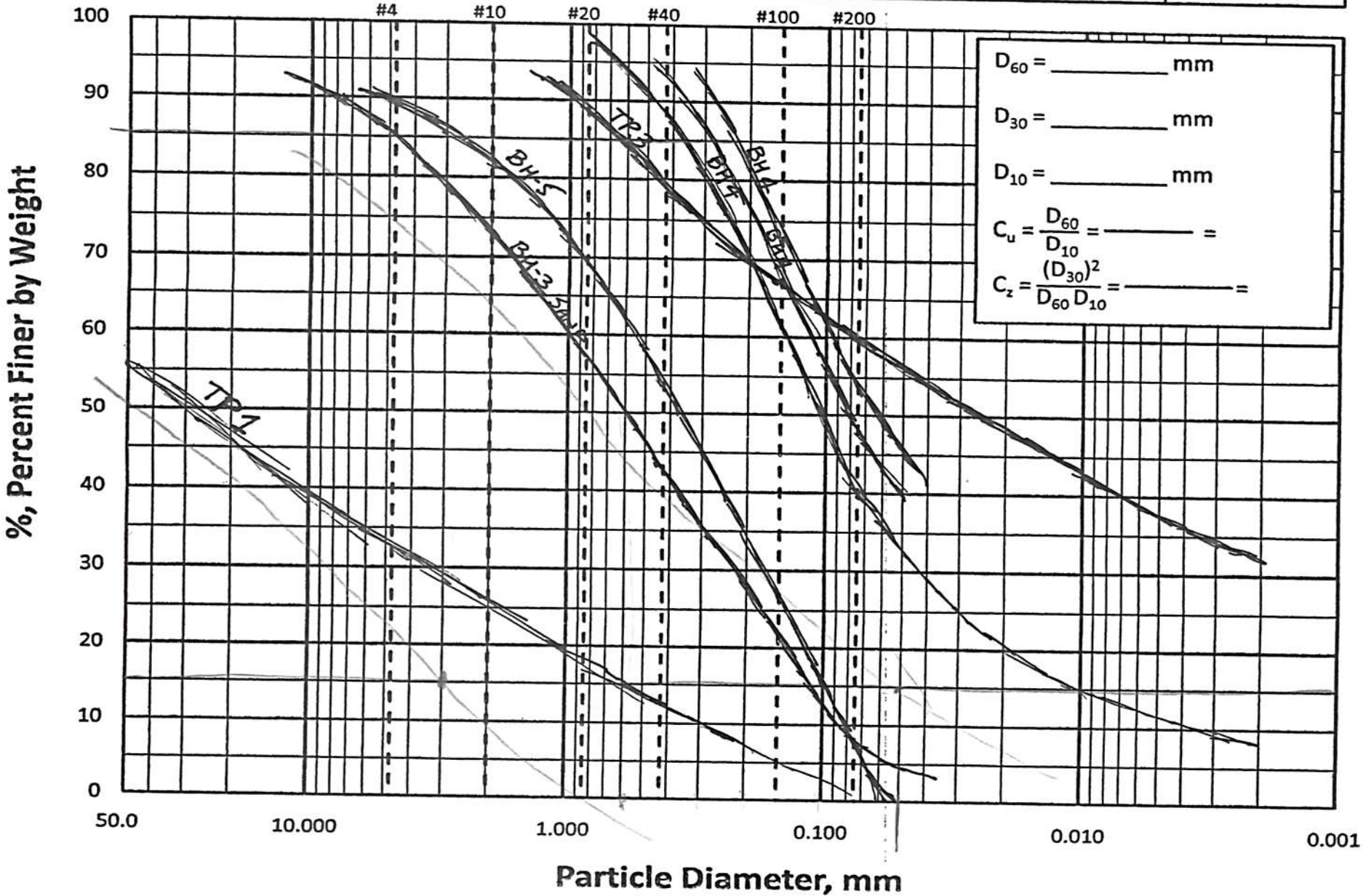

Hydraulic Data

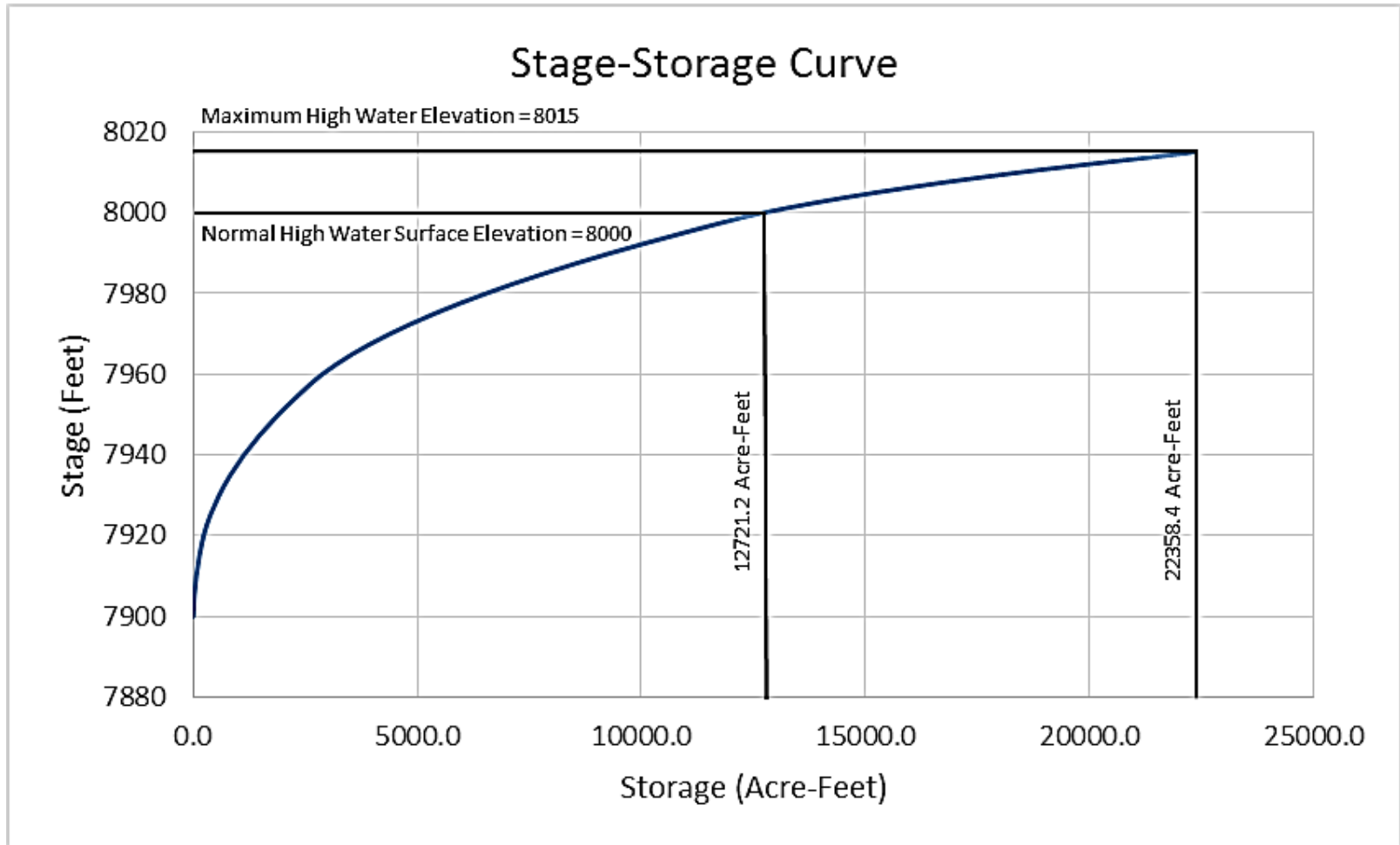

Stage-Area Curve

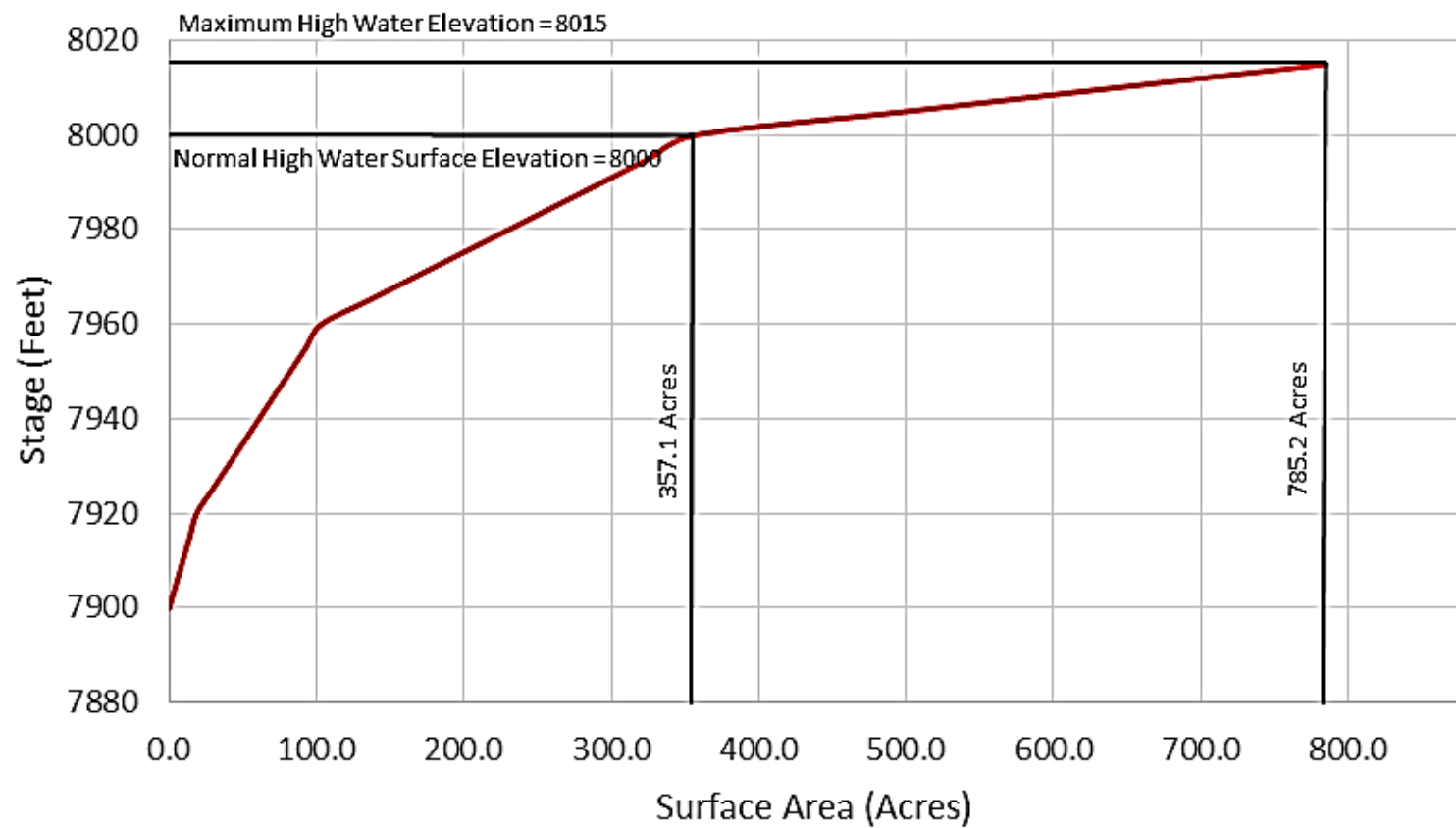

Hydrologic Data

- Inflow design flood
 - Primary spillway – 24hr 100 year NOAA
 - Emergency spillway – 24hr PMP HMR55a
- Mean annual runoff of drainage basin
 - 3650 cfs
- Design values
 - Primary spillway – 2267 cfs
 - Auxiliary spillway – 22750 cfs
- Climatic conditions
 - Dry continental climate with cold winters and warm summers

PMF Hydrographs

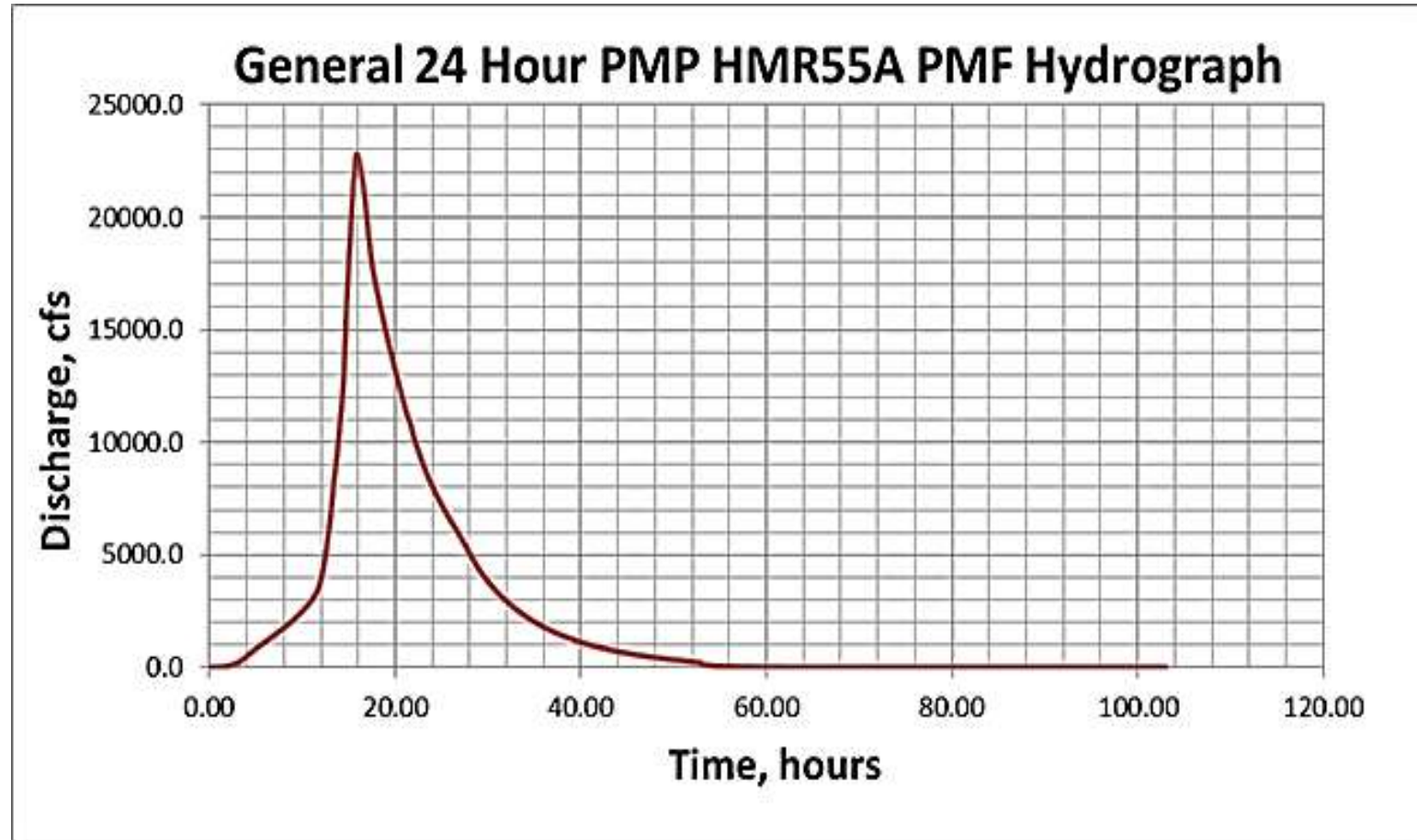

General 24 Hour 100 Year NOAA PMF Hydrograph

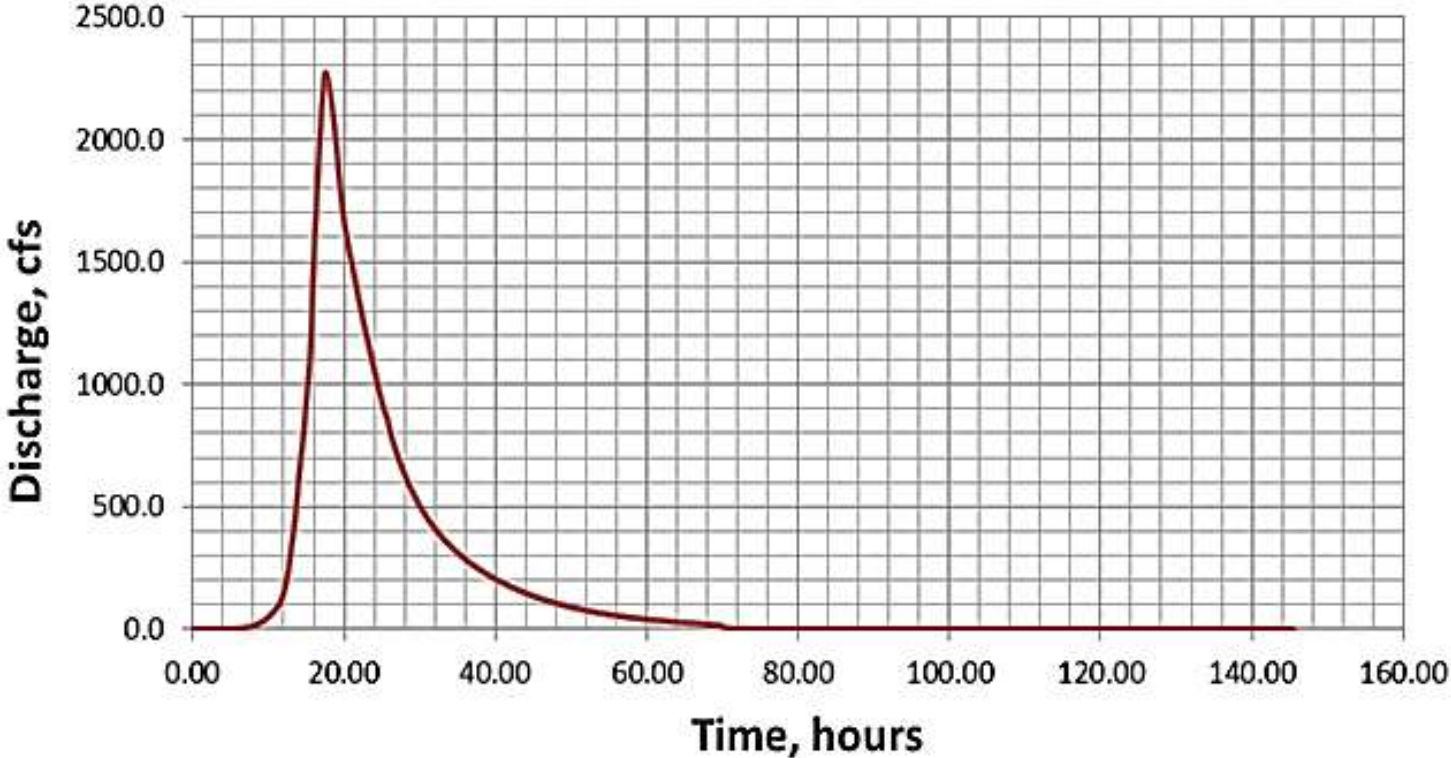

General 24 Hour 25 Year NOAA PMF Hydrograph

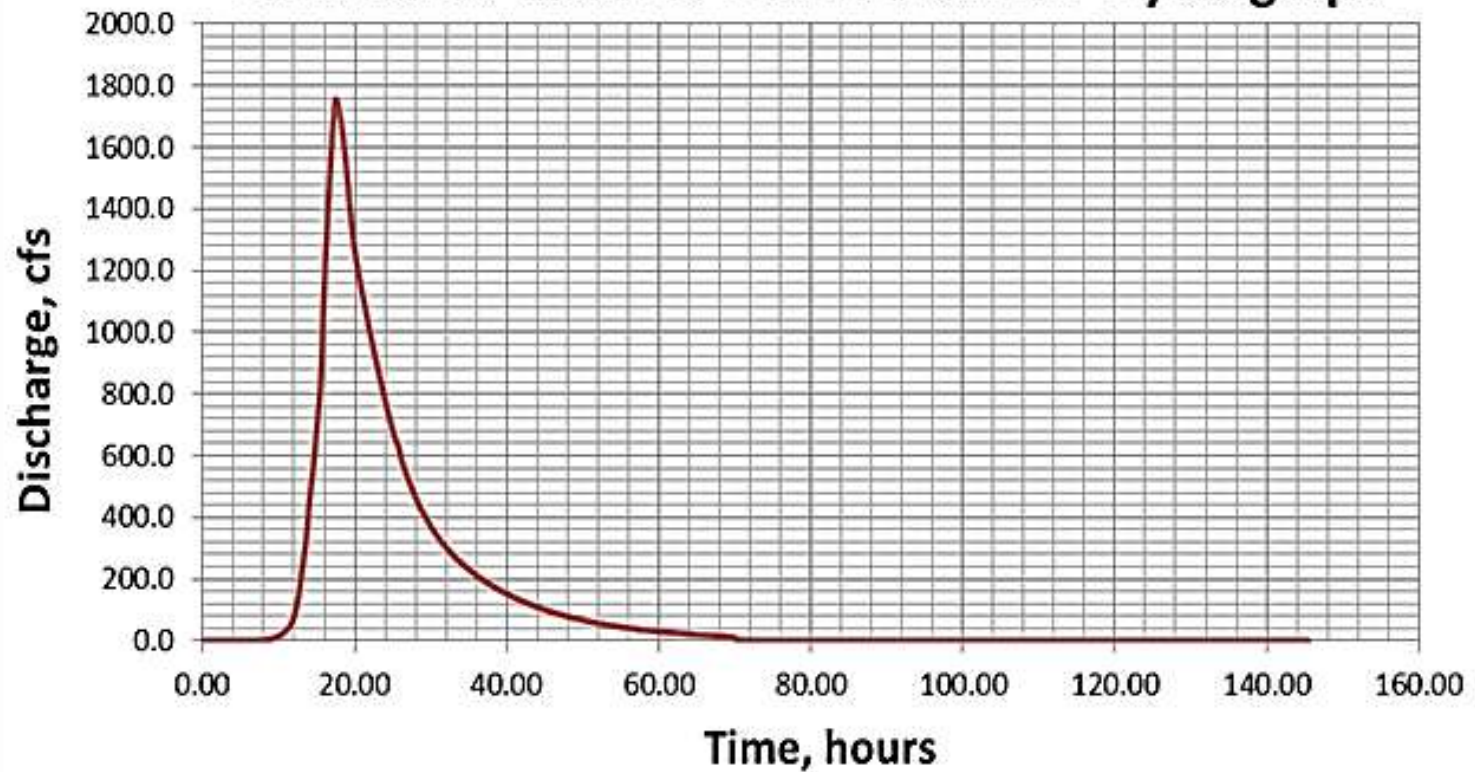



Reservoir Data

- Normal Capacity: 12721 acre-feet
- Water surface elevation: 8000
- Dimensions: 10850 feet x 4000 feet
- Structures affected
 - Upstream: Williams #2 dam
 - Downstream: UP Railroad, KP Ranch, Bath Ranch
- Area that will be flooded is prairie, minor tree removal near stream may be required
- Relocations are not necessary

Geology

- General formations
 - Weathered to competent granite bedrock
 - Moderate to massive fracturing
- Factors relating to reservoir losses
 - Moderate to massive fracturing
- There are no contributory springs, deleterious mineral or salt deposits



Damsite Data

- Nature of stream bed and abutments
 - Streambed
 - Moderately fractured granite
 - Possible shear zone at 15 feet
 - Abutments
 - Mixed competent and weathered bedrock
 - Massive vertical fracturing and loose rock



- Subsoil conditions

- Topsoil was observed from 0 feet to 3 to 5 feet, soils consisted of clayey, silty, sand and gravel.
- Below 3 to 5 feet weathered to competent granite bedrock with moderate to massive fracturing was observed. RQD ranges from 65 to 75.
- In test boring B-4 and test pit TP3 topsoil was encountered from 0 to 5 to 9 in. From 5 to 9 in to 14 feet sandy, silty clay was encountered

Dam Design

- Number and types of estimates prepared:
 - 3 locations evaluated based on feasibility and constructibility
- Features governing design:
 - Topography of dam site
 - Proximity to construction materials
 - Accessibility to dam site
- Water surface elevations
 - Normal water surface elevation – 8000
 - Maximum water surface elevation - 8015
- storage capacities
 - Normal water storage – 12721 acre-feet
 - Maximum water storage – 22358 acre-feet
- Freeboard: 5 feet above maximum water level

- General Dimensions
 - Top width: 28 feet
 - Description of sections
 - Slopes
 - Upstream 3:1
 - Downstream 2:1
 - Height above streambed: 120 feet
 - Zoning
 - Zone 1: core, height: 115 feet, base width: 115 feet
 - Zone 2: Shell, height: 120 feet, base width: 628 feet
- Crest Length: 1453 feet
- Length of base at maximum section: 628 feet

Dam Cross-section

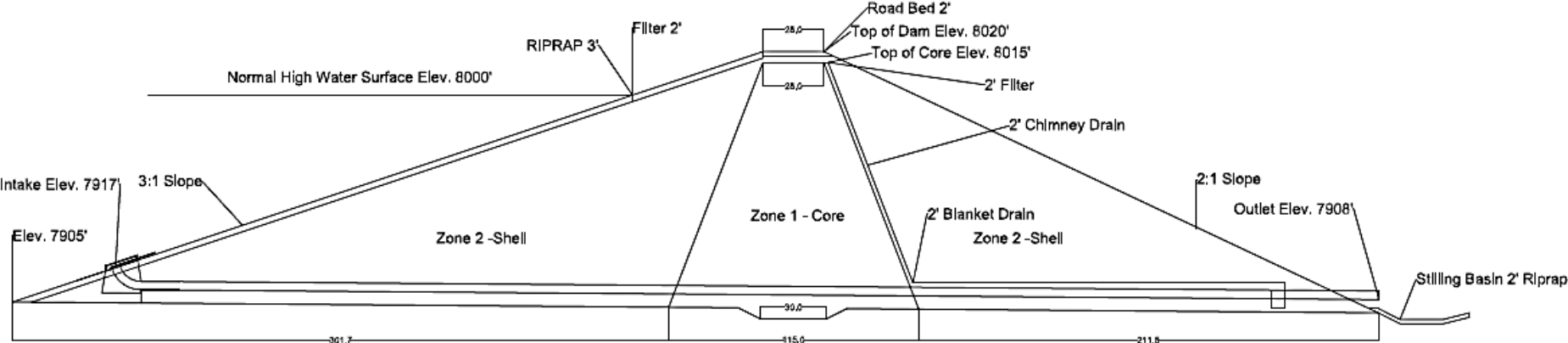

- Cutoff trench dimensions
 - Base width: 30 feet
 - Top width: 50 feet
 - Depth: 5 feet
 - Side slopes: 2:1
- Cutoff wall dimensions
 - 24 feet wide
 - Spans from right abutment to left abutment
- Grouting requirement
 - 3 rows of grout holes spaced 12 feet apart
- Toe drain
 - 12 inch N-12 perforated pipe spanning from right abutment to left abutment draining into the stilling basin

Cutoff Trench

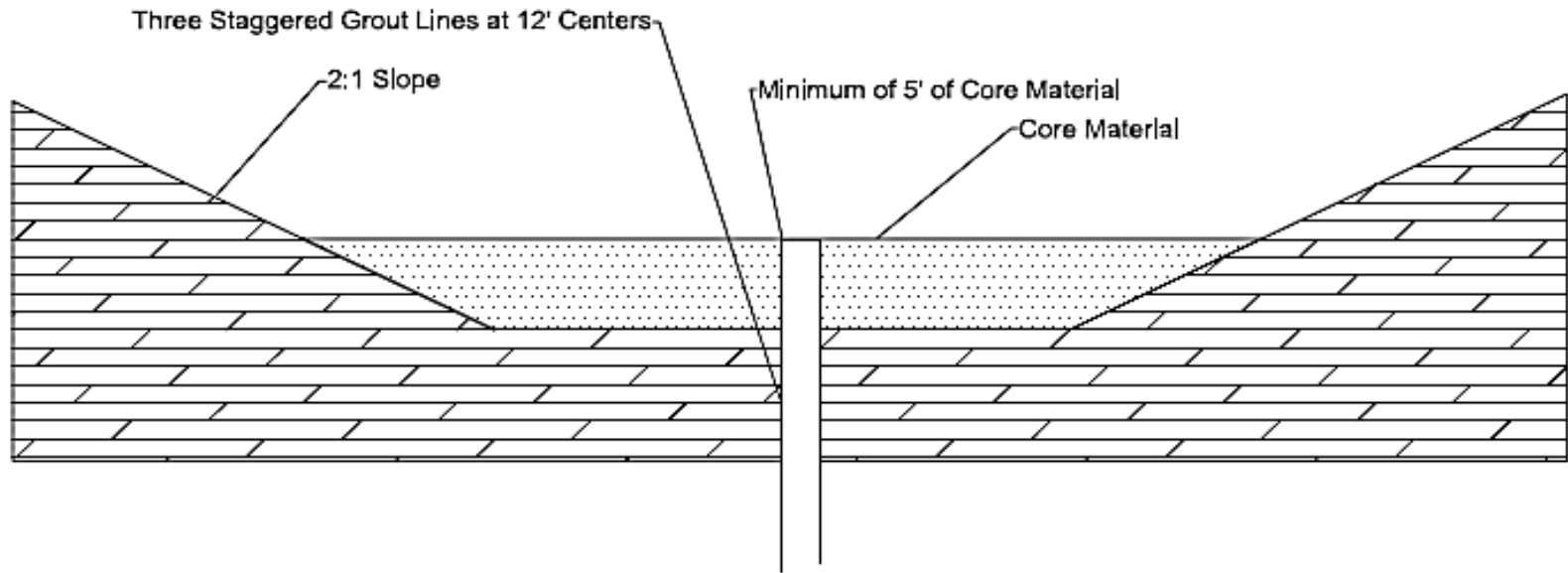

Dam and Toe Drain Profile

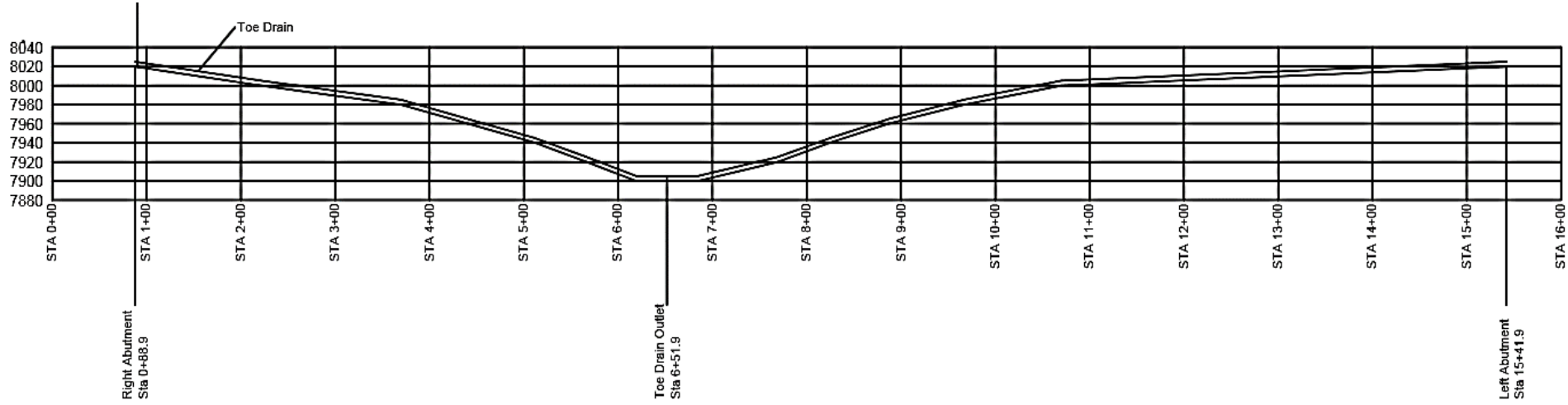

Toe Drain

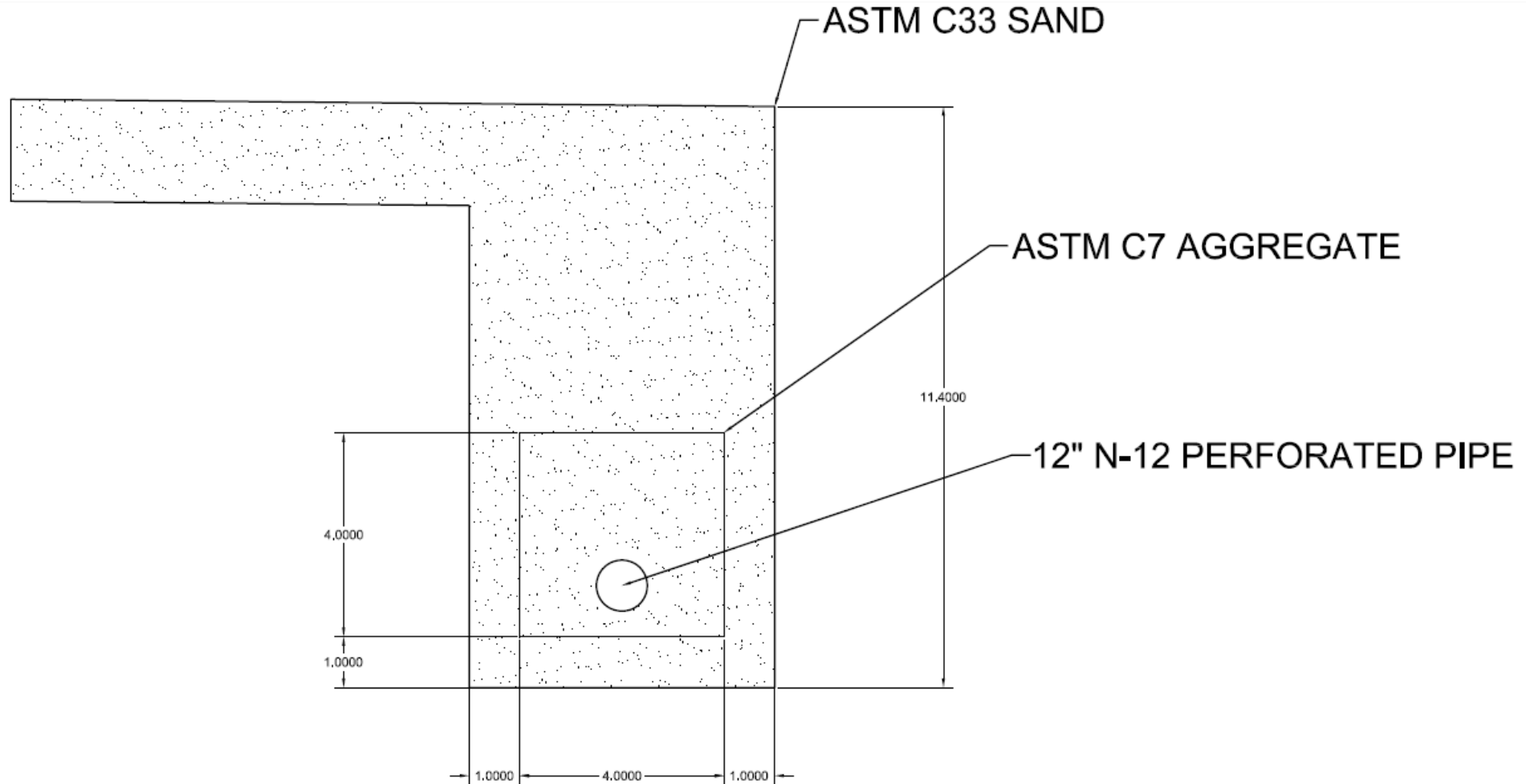

Outlet Works Design

- Requirements
 - A computation of capacity and all necessary data
 - Must be able to release half of water in 30 days
 - During an emergency a foot a day drawdown rate must be achieved
- Discharge: 180 cfs
 - Water surface elevation: 8000
- Factors affecting location
 - Topography
 - Ability to drain reservoir for maintenance
 - Above reservoir bottom to prevent sedimentation

Discharge Rating

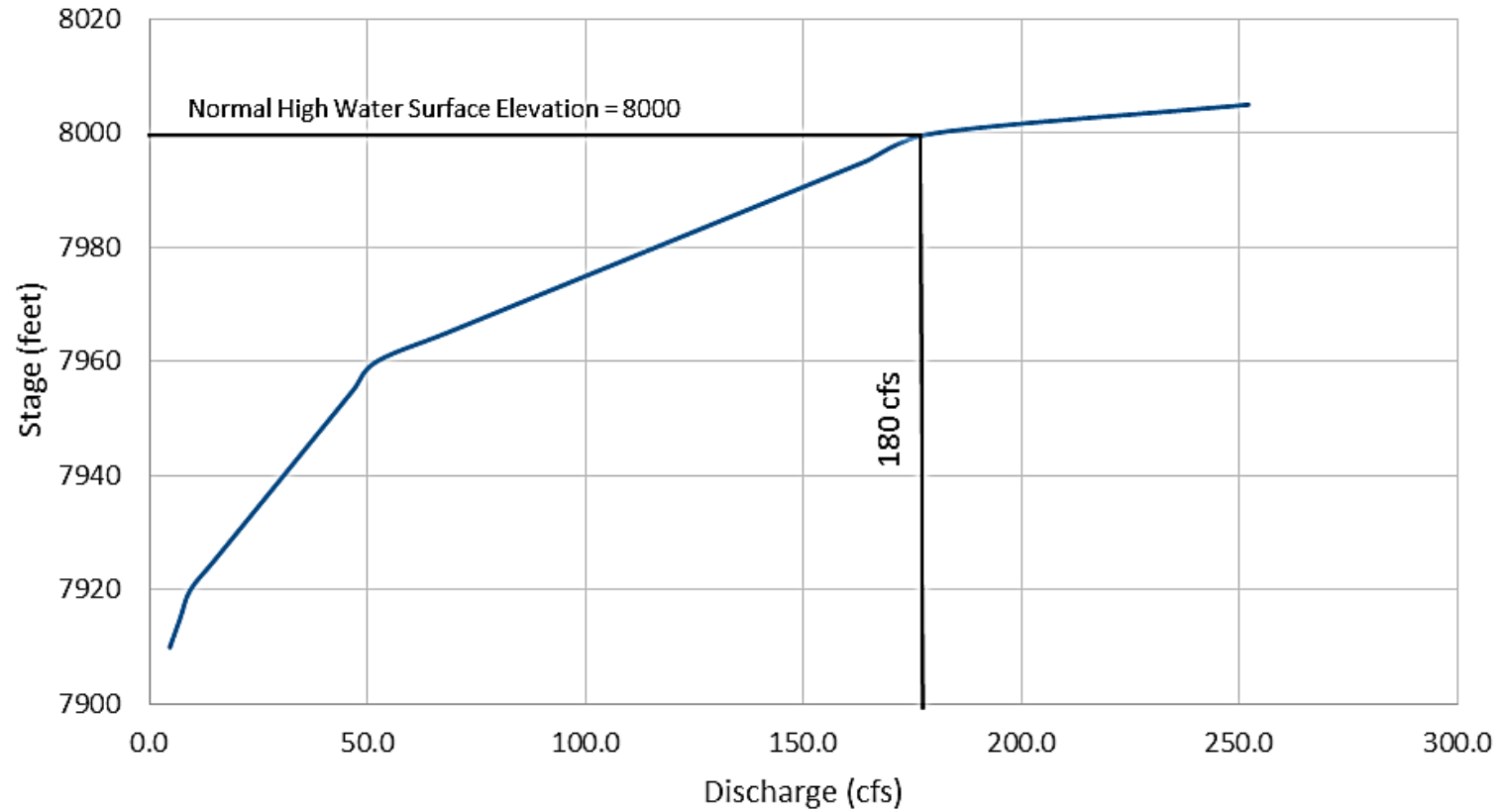

- Gate chamber
 - Dimensions: 15 feet by 8 feet
 - Location: Centered on upstream face of dam, 12 feet above base of dam
 - Accessible when reservoir is drained
- Gate valve
 - 8.6 feet by 6 feet, 4 in stem casing
 - Elevation: 7917 feet
- Pipes
 - 42 inch outlet works pipe
 - 4 inch vent pipe
 - Exit elevation: 7908 feet
- Location of controls: Crest of dam
- Trashrack: 4 in galvanized pipe on 18 inch centers
- Stilling basin: 3 feet thick rip rap on aggregate filter

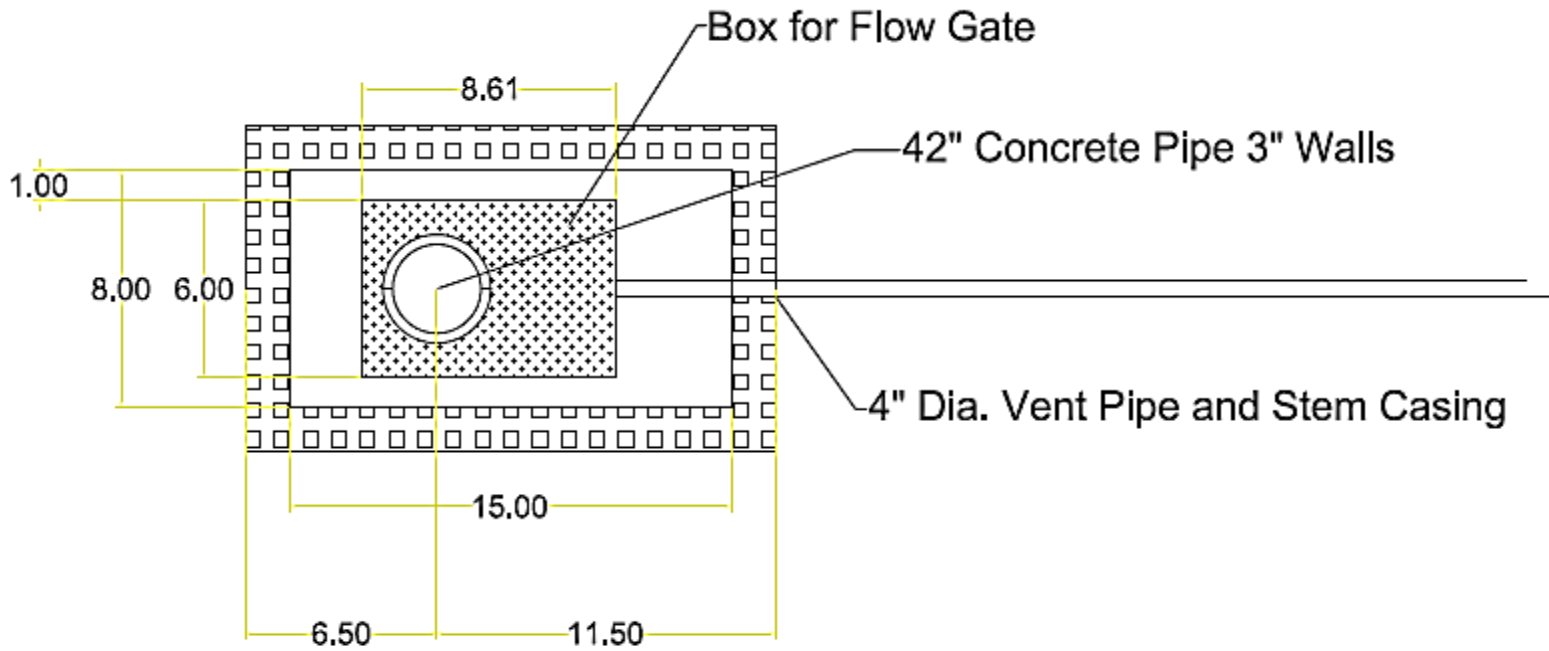
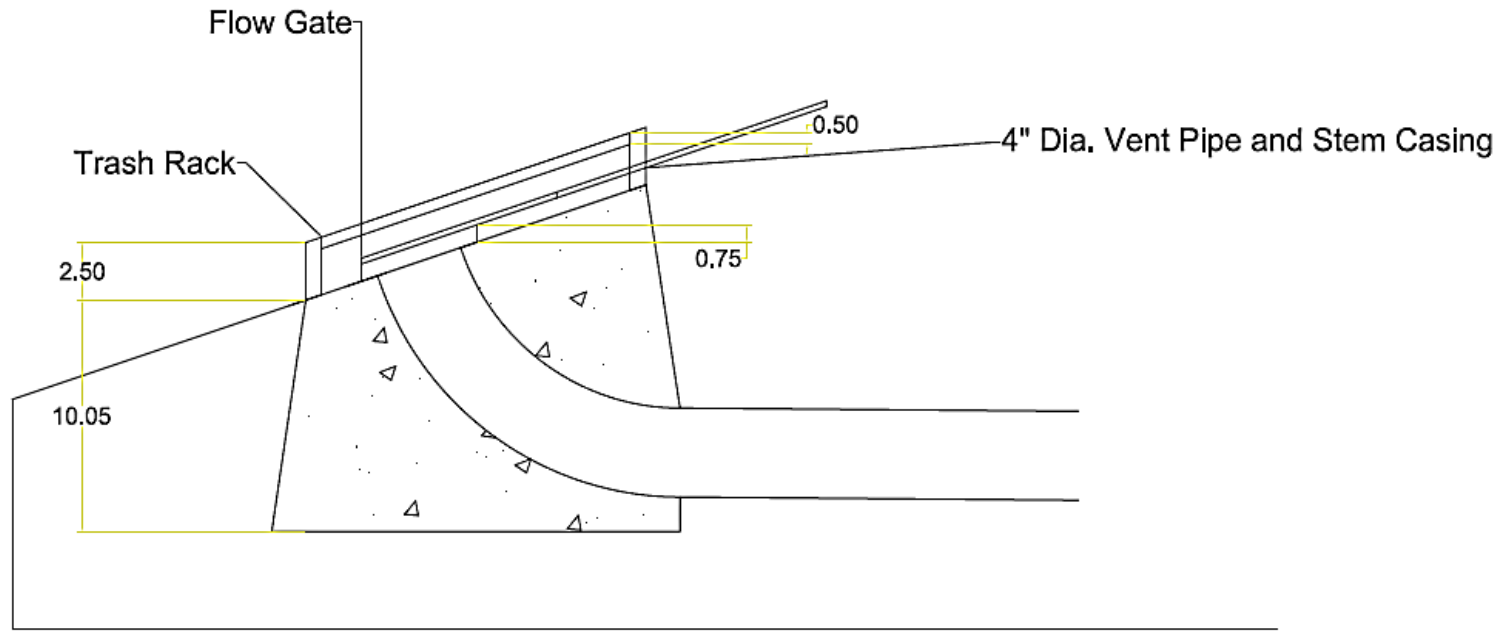

Stilling Basin

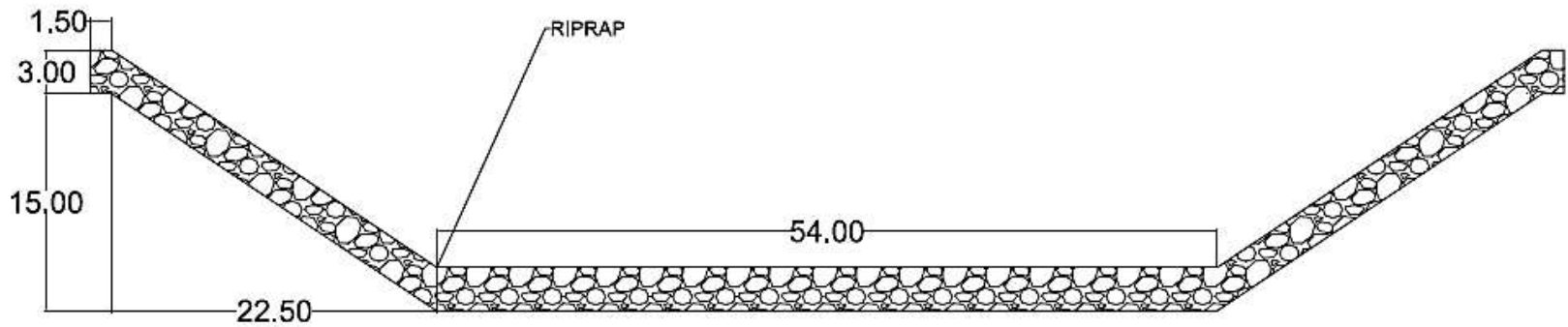

Spillway Design

- Requirements
 - Computation of capacity and all necessary data
 - Sufficient capacity to pass the flood flow for a projected 100 year storm
 - Minimum 1.5 feet of freeboard, between the top of the dam and the maximum water level in the spillway, is maintained
 - If erosive velocities in spillway channel, a lining shall be added or redesign of the spillway

- Factors governing design and location
 - Topography
 - Ability to discharge a safe distance from the toe of the dam
- Primary Spillway
 - Uncontrolled Ogee Crest
 - Concrete lined
 - 55 feet wide
 - Top of Ogee crest elevation: 8000 feet
 - Concrete approach and discharge channel, discharging into natural drainage
- Auxiliary Spillway
 - Uncontrolled broad crested weir
 - 450 feet wide
 - Top of weir elevation: 8005 feet
 - Native material approach and discharge channel, discharging into natural drainage

Primary Spillway

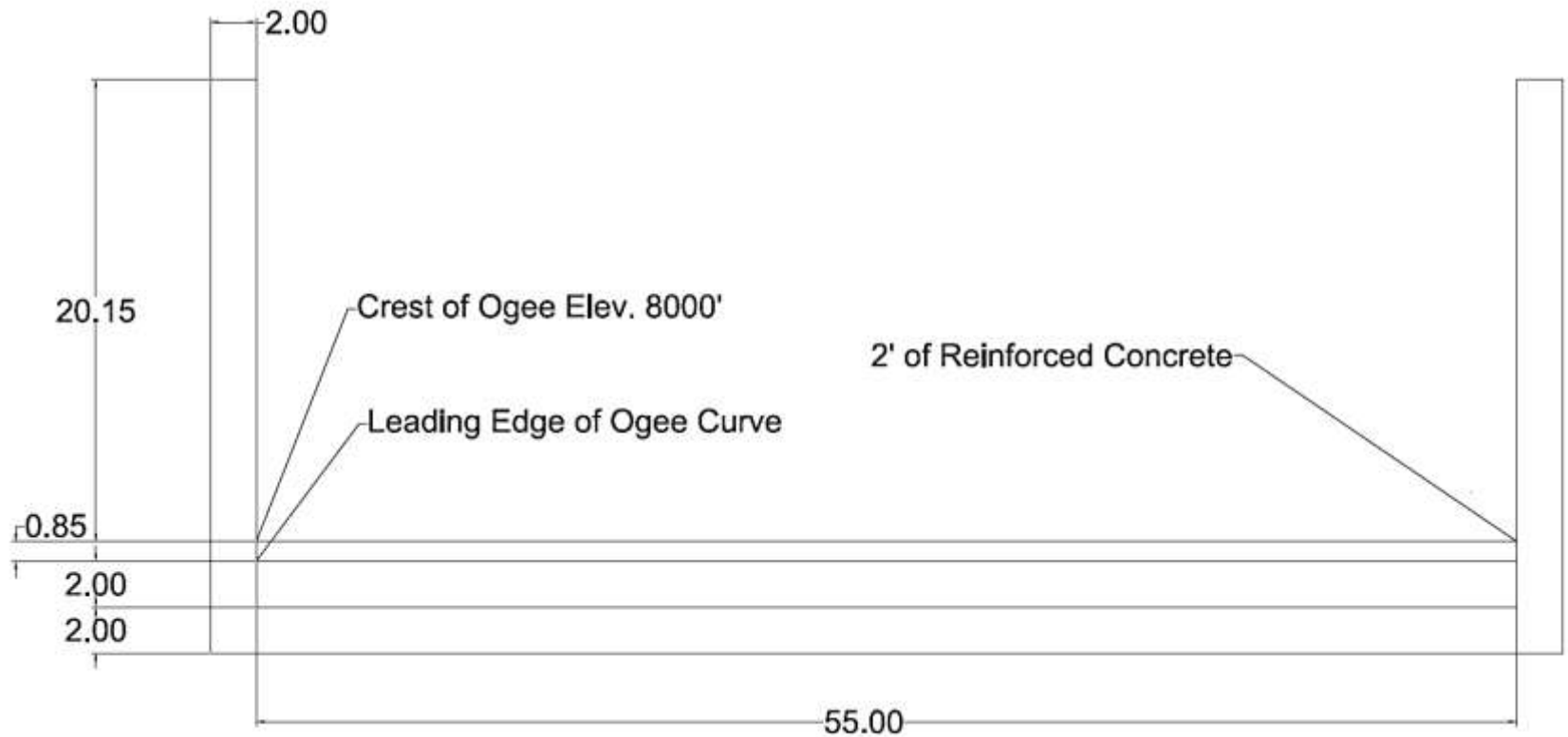
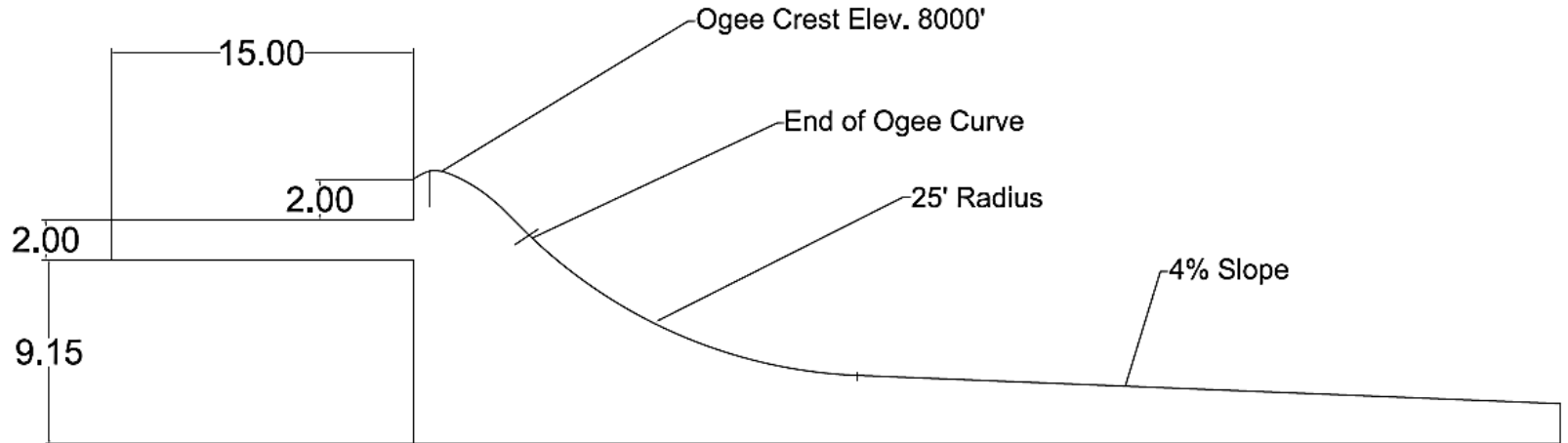

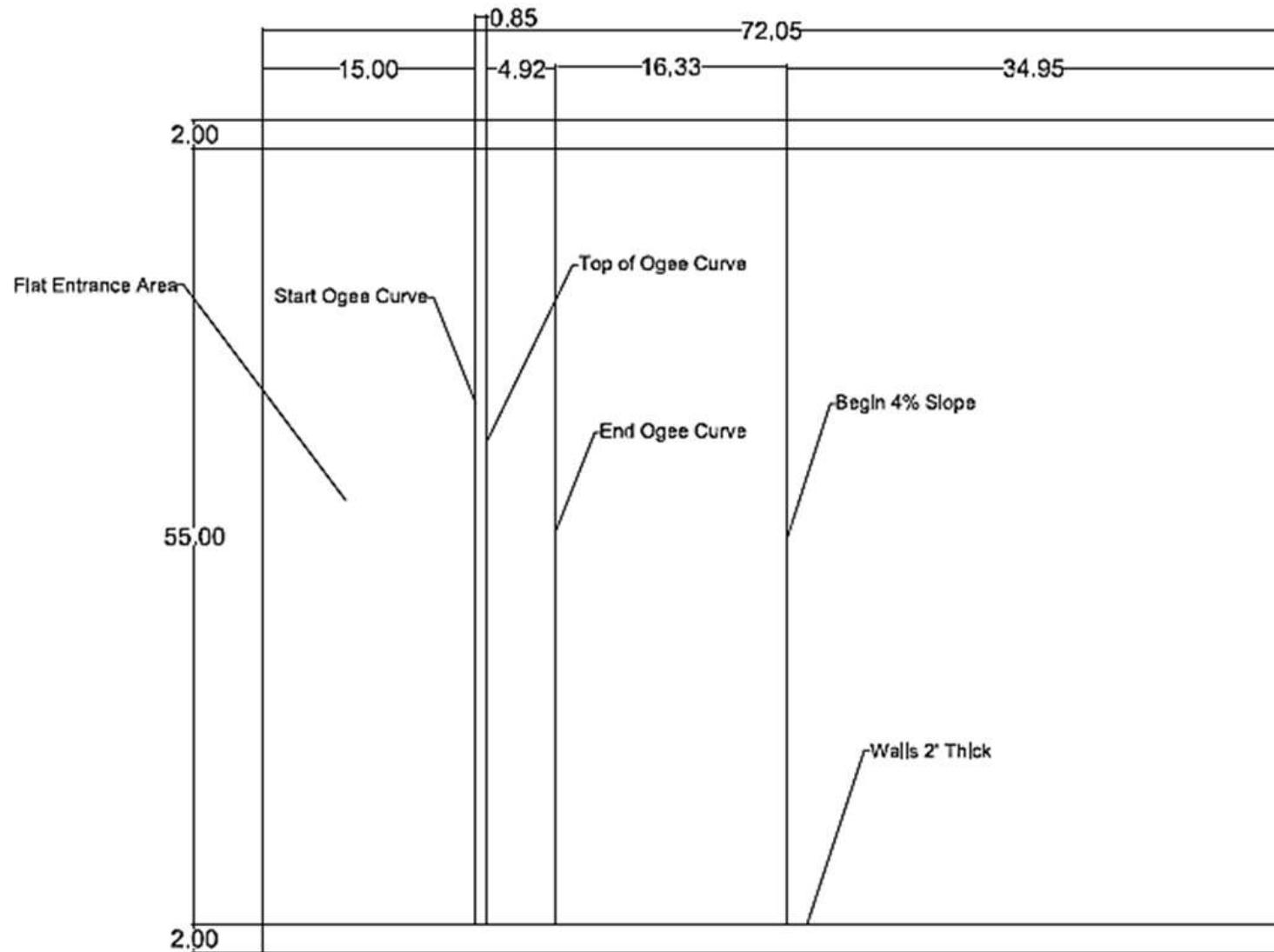

Auxiliary Spillway

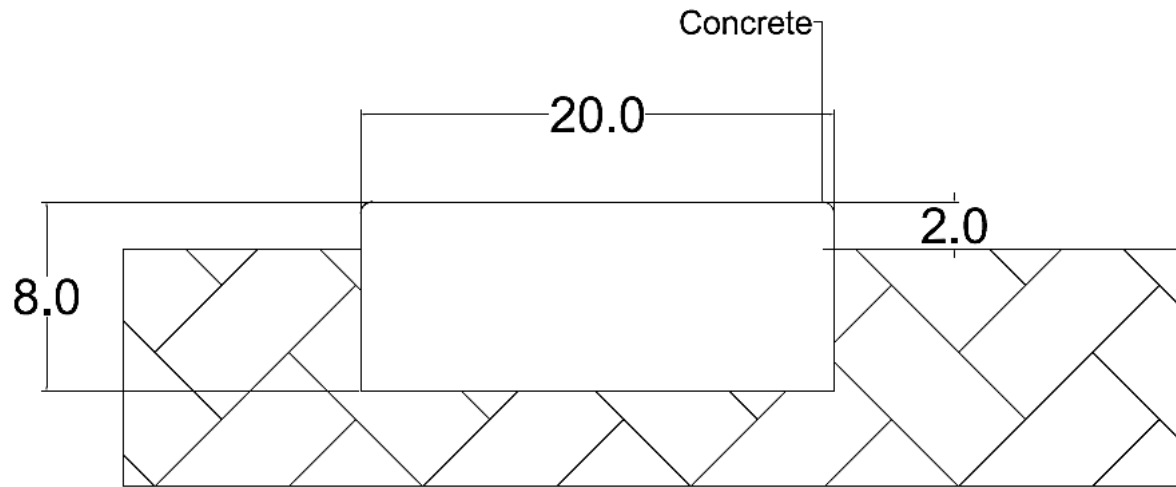

Construction Facilities

- Estimated time to completion
 - one construction season
- Power is available from local power lines
- Shipping points and hauls are available and adequate
- Construction camp will not be not needed
- Local conditions
 - Cold winters with high snow and warm summers with little rain
 - High altitude

Materials and Unit Prices

- Location of borrow, hauls
 - On site and local
- Aggregate deposits, hauls
 - On site and local
- Cement, nearest mills, hauls
 - Mountain cement and local
- Railroads
 - Union Pacific Railroad Company
- Basis for unit pricing
 - Blue Book, Building and construction

Environmental and Ecological Measures

- Fish and wildlife protection
 - No fish habitat
 - Minimal wildlife impact
- Fish and wildlife development
 - Stock reservoir with fish
- Recreational development plans
 - Possible boat access and picnic area
- Environmental protection measures during construction
 - Silt fences along stream
 - Designated staging area for equipment and machinery

Conclusion

Summary

- Location and Purpose
- Summary of Design
- Design Data
 - Reservoir
 - Dam site
- Design
 - Dam
 - Outlet Works
 - Spillway
- Construction Facilities
- Materials and Unit Prices
- Environmental and Ecological Measures
- Conclusion



Questions?

References

Chen, David. "Flow in Open Channels." *Water-Resources Engineering*. 2nd ed. Upper Saddle River: Pearson Prentice Hall, 2006. 158-179. Print.

Design of Small Dams. 3rd ed. Washington, D.C.: U.S. Dept. of the Interior, Bureau of Reclamation :, 1987. Print.

"Hydrometeorological Report No. 55A." *Hydrometeorological Design Studies Center*. National Oceanic and Atmospheric Administration, 1 Jan. 1988. Web. April 16, 2015. <<http://www.nws.noaa.gov/oh/hdsc/studies/pmp.html>>.

Surface Water Regulations and Instructions. Cheyenne, WY: Wyoming State Engineer's Office:, 1974. Web. April 25, 2015. <<https://sites.google.com/a/wyo.gov/seo/regulations-instructions#Surface>>