

Dustin Bales
Danial Barkhurst



Brady Wagner
Patrick Quaglieri

2014 Happy Jack Racing Baja Design



Goal
Aeolus Powertrain was tasked with designing and constructing the powertrain components for the 2014 University of Wyoming Baja vehicle. These components were designed to transfer the engine power to the wheels with upmost efficiency to make the 2014 UW Baja vehicle competitive with some of the best engineering schools in the world.

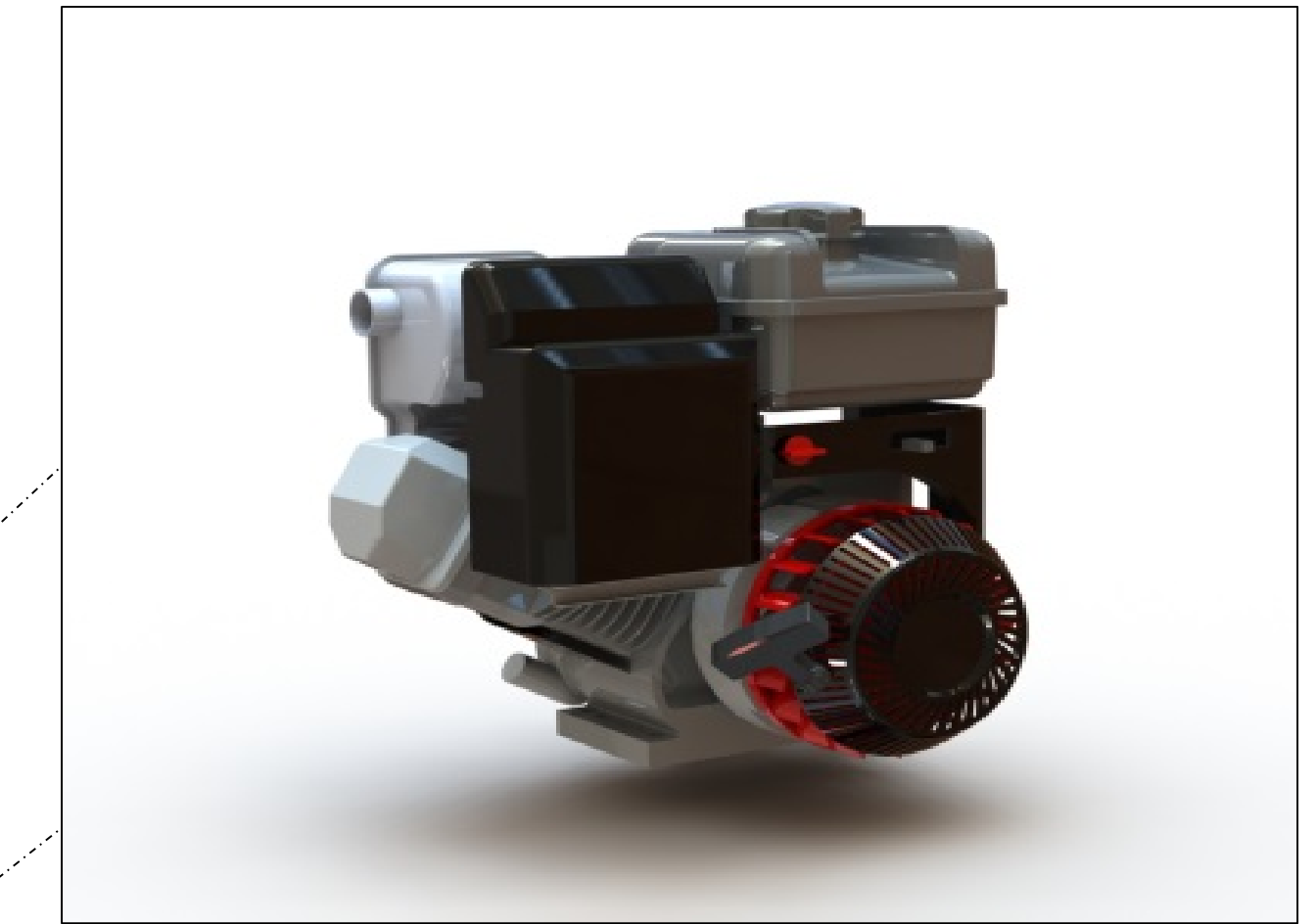

Briggs and Stratton OHV Intek

- 10 HP
- 3800 Peak RPM
- Required by SAE Baja for competition

CVTech Clutch Set

- Continuously Varying Transmission allows for an infinite speed reduction ratio within range
- 3.0:1 Initial Shift Ratio
- 0.43:1 Final Shift Ratio
- Tuning capabilities allow specialized shift characteristics based on terrain

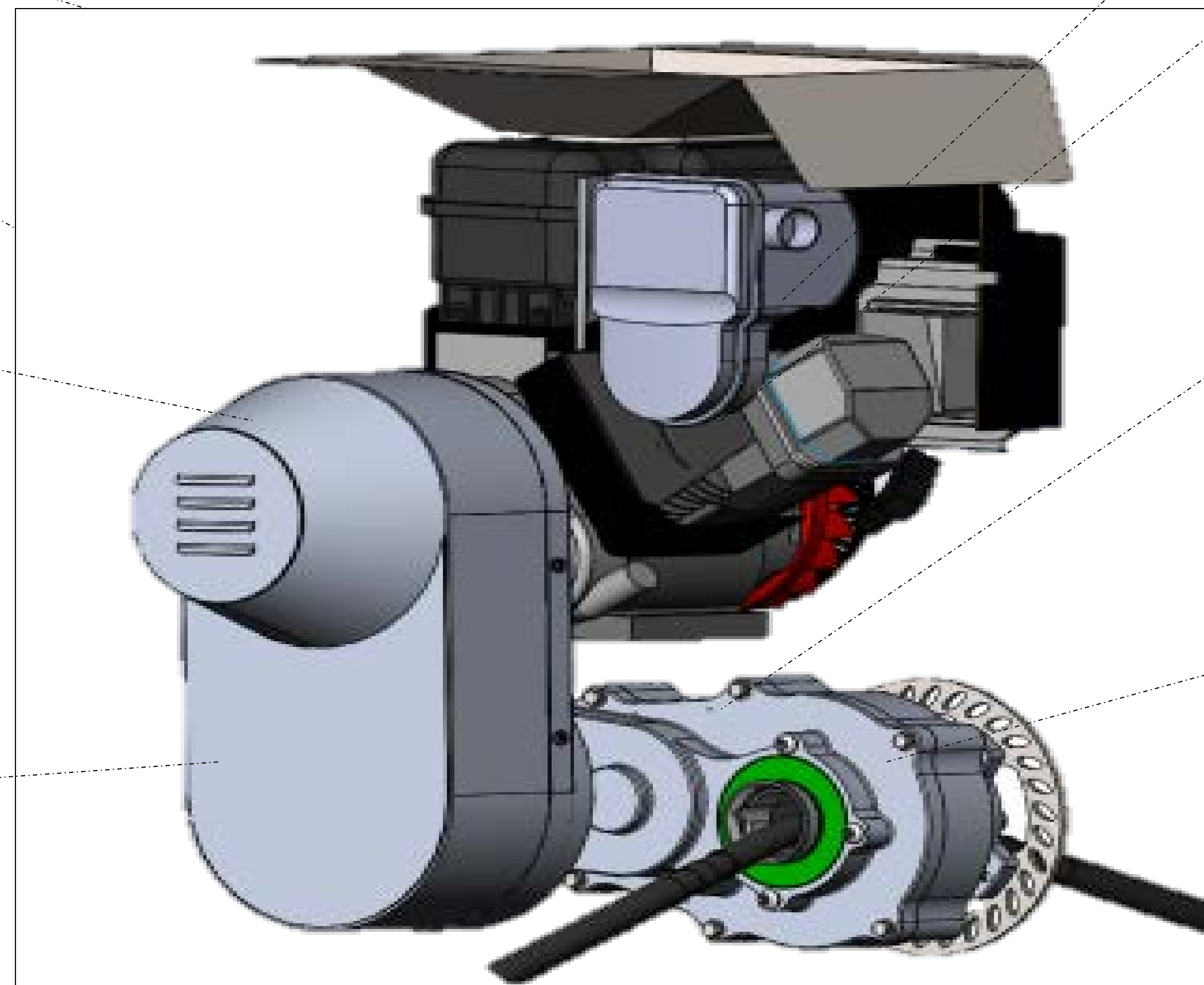

Custom Aluminum Gearbox

- Houses 9 inch disc brake for compact system
- Self contained gear train with oil bath

Completed 2014 Happy Jack Racing Baja



- Double reduction gear train and sprocket set
- 13.4:1 Speed Reduction



Custom Steel 4140 Output Shaft

- allows for 13 inches of rear suspension travel
- Trans-axle with Independent Rear Suspension